



HydrauPack 200E

Features

- Electric driven open loop hydraulic power unit
- Flow or pressure pump control in single or dual mode
- Lloyd's Register offshore certified acc. to DNV rules 2.7-1 CSC and EN12079 incl. rigging
- UDP/analog connection for electronic remote control
- Integrated hydraulic air/oil cooler
- Parallel operation with other HP200E or HP1500E units for higher output flow

Benefits

- 24/7** 24/7 (de)mobilisation, installation and commissioning
-  Maintenance during the project
-  Guaranteed flexibility and high availability
-  Clear budget and manageable costs

Specifications HP200E

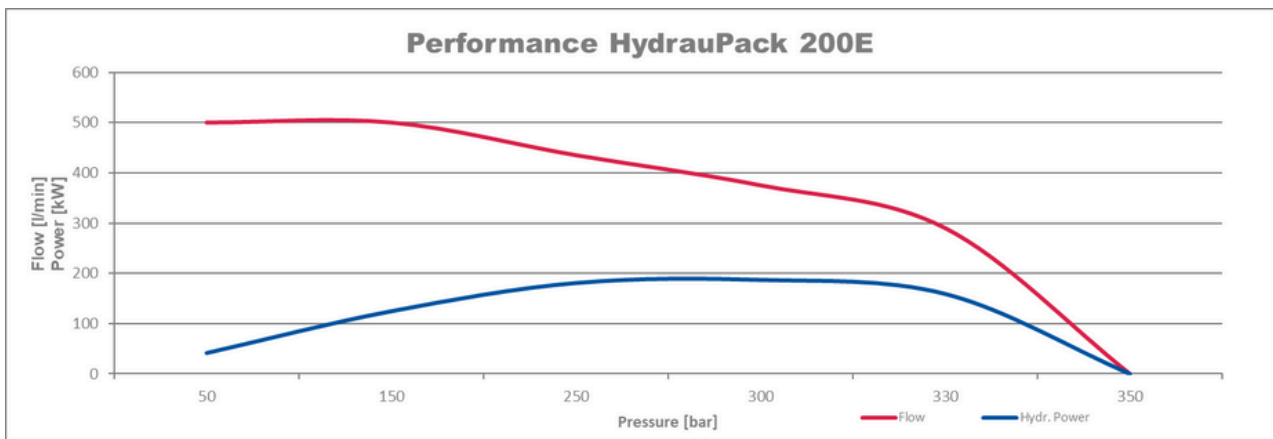
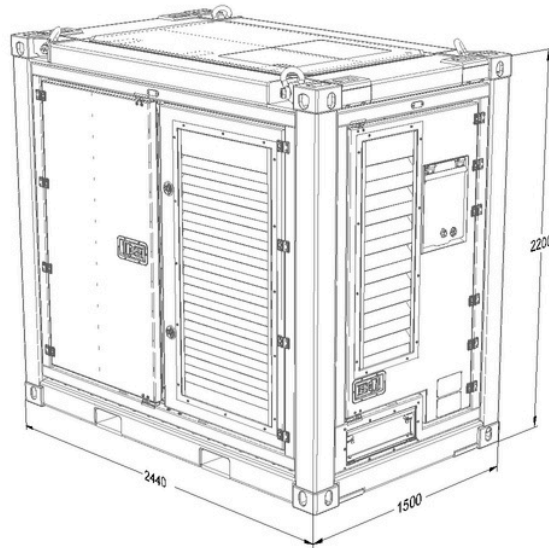

Specifications

Total weight excl./incl. oil	5900 / 6500	kg
Hydraulic oil tank capacity	850	liter
Operational temperature	-20 to +40	°C

Technical specifications

Max. working pressure	350	bar
Max. output flow @ 350 bar	350	liter/min
Max. output flow	500	liter/min (variable up to 200 bar)
Electric motor power	2 x 110	kW @ 440/690 VAC (50-60 Hz)
Flush capacity	24	liter/min @ max 30 bar
Cooling capacity	80	kW (air temp. 45 °C)
Hydraulic fluid	H(V)LP ISO VG 46, 68	
Power supply nominal	2 x 400 VAC (50 Hz) - 210A (3P + E) 2 x 440 VAC (60 Hz) - 190A (3P + E) 2 x 690 VAC (60 Hz) - 130A (3P + E)	
Power connections	Powerlock NPS-1-BN-T4 Phase 1 Powerlock NPS-2-BN-T4 Phase 2 Powerlock NPS-3-BN-T4 Phase 3 Powerlock NPS-E-BN-T4 Earth	
Pressure (P)	QC 2" Stucchi VOF200 2 BSP N	
Return (T)	QC 2" TEMA T20020 Male	
Drain (D)	QC 1-1/2" TEMA T15020 Male	
Flush (F)	QC 1/2" Snap-tite 71-3 N 8-8 RP	